

SOLDER JACK RECEPTACLE
HERMETIC - WITH CYLINDRICAL CONTACT

R125.630.000

Series : SMA

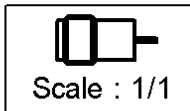
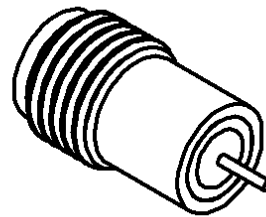
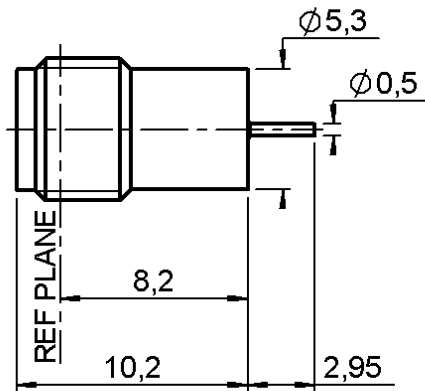

All dimensions are in mm.

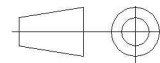

COMPONENTS	MATERIALS	PLATINGS (µm)
BODY	FERRO-NICKEL	GOLD 0.5 OVER NICKEL 2
CENTER CONTACT	DILVER P	GOLD 0.5 OVER NICKEL 2
OUTER CONTACT	-	-
INSULATOR	PTFE	-
GASKET	-	-
OTHERS PARTS	-	-
-	-	-
-	-	-

Issue : 0431 E

In the effort to improve our products, we reserve the right to make changes judged to be necessary.



SOLDER JACK RECEPTACLE

R125.630.000

HERMETIC - WITH CYLINDRICAL CONTACT

Series : SMA

PACKAGING

SPECIFICATION

Standard	Unit	Other
1	-	Contact us

ELECTRICAL CHARACTERISTICS

Impedance		50 Ω
Frequency		0-18 GHz
VSWR	1.10 * +	0.010 x F(GHz) Maxi
Insertion loss		0.3* √F(GHz) dB Maxi
RF leakage	- (NA - F(GHz)) dB Maxi
Voltage rating		500 Veff Maxi
Dielectric withstanding voltage		1000 Veff mini
Insulation resistance		5000 MΩ mini

ENVIRONMENTAL

Operating temperature	-40/+100 ° C
Hermetic seal	10-5 Atm.cm ³ /s
Panel leakage	NA

OTHERS CHARACTERISTICS

Assembly instruction

Others :

* Coaxial Transmission Line Only

MECHANICAL CHARACTERISTICS

Center contact retention		
Axial force – Mating end		27 N mini
Axial force – Opposite end		27 N mini
Torque		NA N.cm mini
Recommended torque		
Mating		NA N.cm
Panel nut		NA N.cm
Mating life		500 Cycles mini
Weight		1.200 g

Issue : 0431 E

In the effort to improve our products, we reserve the right to make changes judged to be necessary.



SOLDER JACK RECEPTACLE

R125.630.000

HERMETIC - WITH CYLINDRICAL CONTACT

Series : SMA

RECOMMENDED MOUNTING HOLE DETAIL

PANEL WITH THROUGH HOLE

Frequency range 0 – 18 GHz
 VSWR < 1.10 + 0.03 F

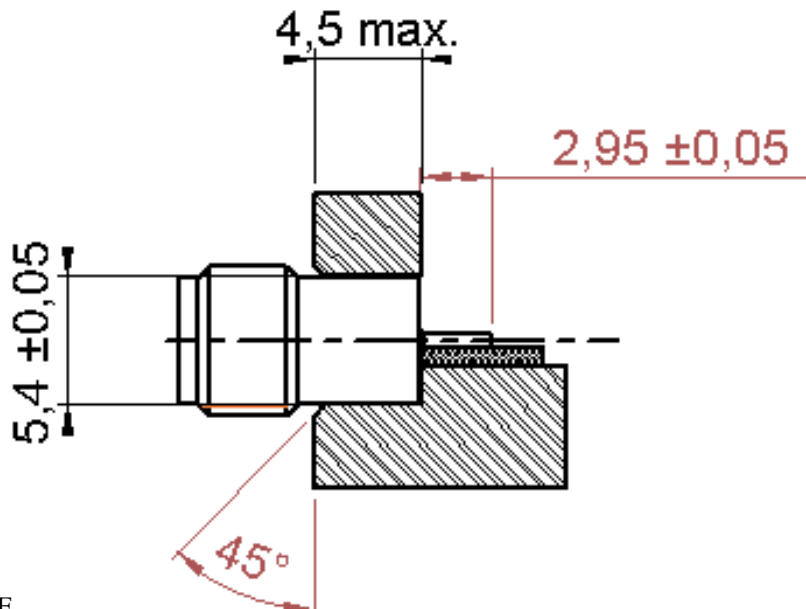

PANEL WITH BLIND HOLE

Frequency range 0 – 18 GHz
 VSWR < 1.05+0.02F

1 to 2.4 according
 to customer's application

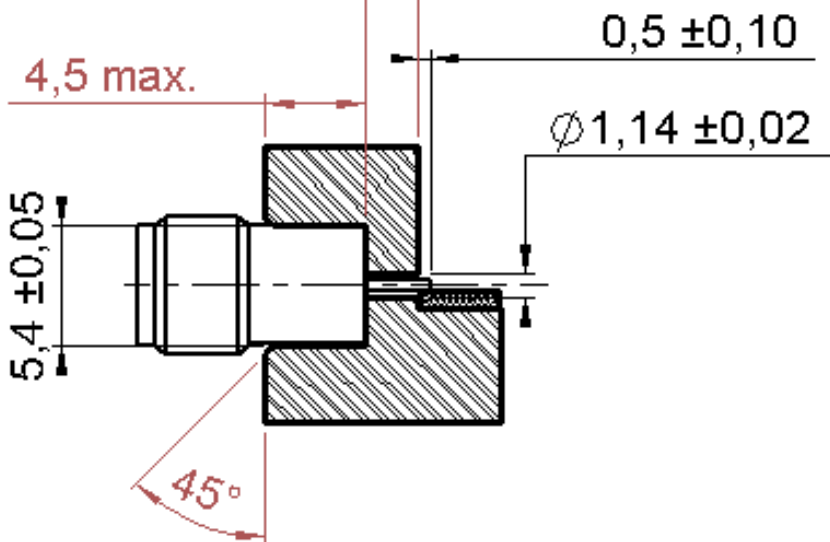

Issue : 0431 E

In the effort to improve our products, we reserve the right to make changes judged to be necessary.



SOLDER JACK RECEPTACLE
HERMETIC - WITH CYLINDRICAL CONTACT

R125.630.000

Series : SMA

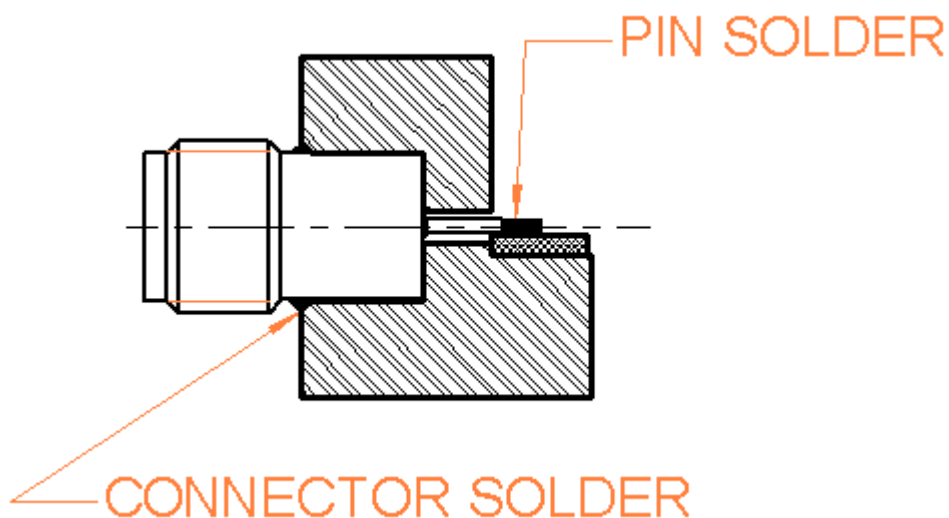
MOUNTING INSTRUCTIONS

- 1 – Degrease and clean connector and box.
- 2 – Solder the connector on the panel:
Preheating at about 100°C.
Take care not to exceed 250°C during solder operation .
- 3 – Solder the pin on the track:
-ceramic substrates: preheating at about 100°C.
-other substrates: no preheating required.

NOTE: Please use a small soldering iron ,or hot air soldering system.

- 4-Mount the insulator in accordance with the drawing:
used the dielectric insert tool and the dielectric plunger R282.730.043.

Issue : 0431 E

In the effort to improve our products, we reserve the right to make changes judged to be necessary.

